

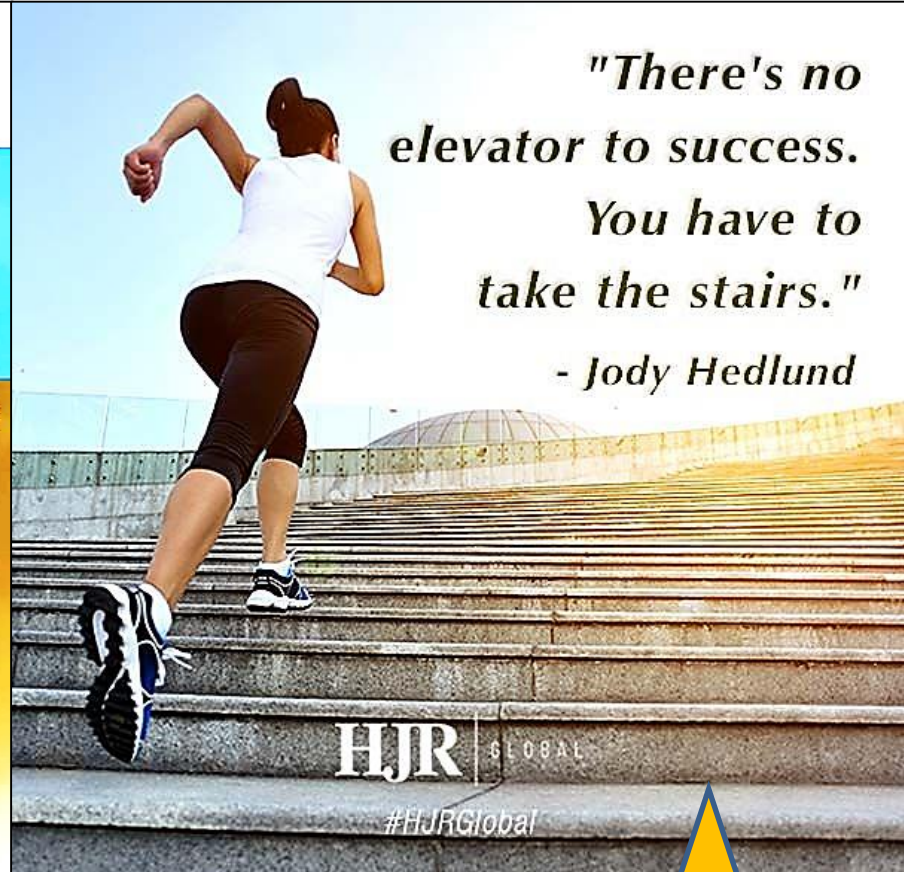

Think positive

Believe in yourself!

@thinkgrowrise



Cell Bio-2

Microtechniques

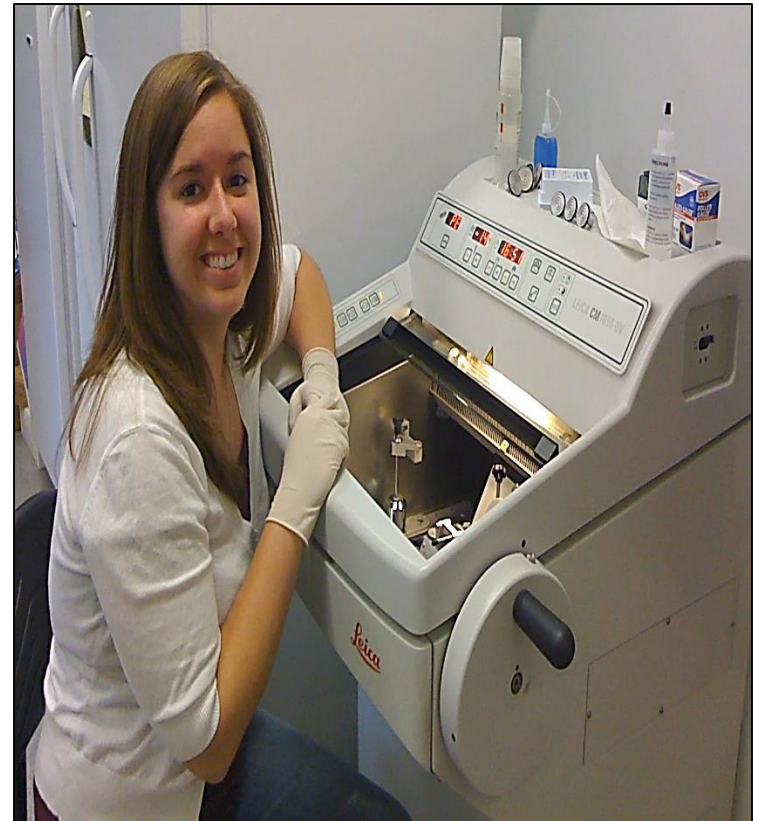

Micro techniques For Light microscopy

To preserve the structure and chemical composition of the specimen

I
Paraffin

II
Freezing

I: Paraffin technique

- Technique used to prepare **the tissues** for light microscopy
- it includes the following steps:
 - 1. Fixation** : in appropriate solution (formol saline)
 - 2. Dehydration and clearing** : in alcohol then xylol
 - 3. impregnation & Embedding** : in paraffin wax (Soft & hard)
 - 4. Sectioning** : by microtome
 - 5. Mounting** : on glass slides
 - 6. Staining of the sections**

Tissue processing

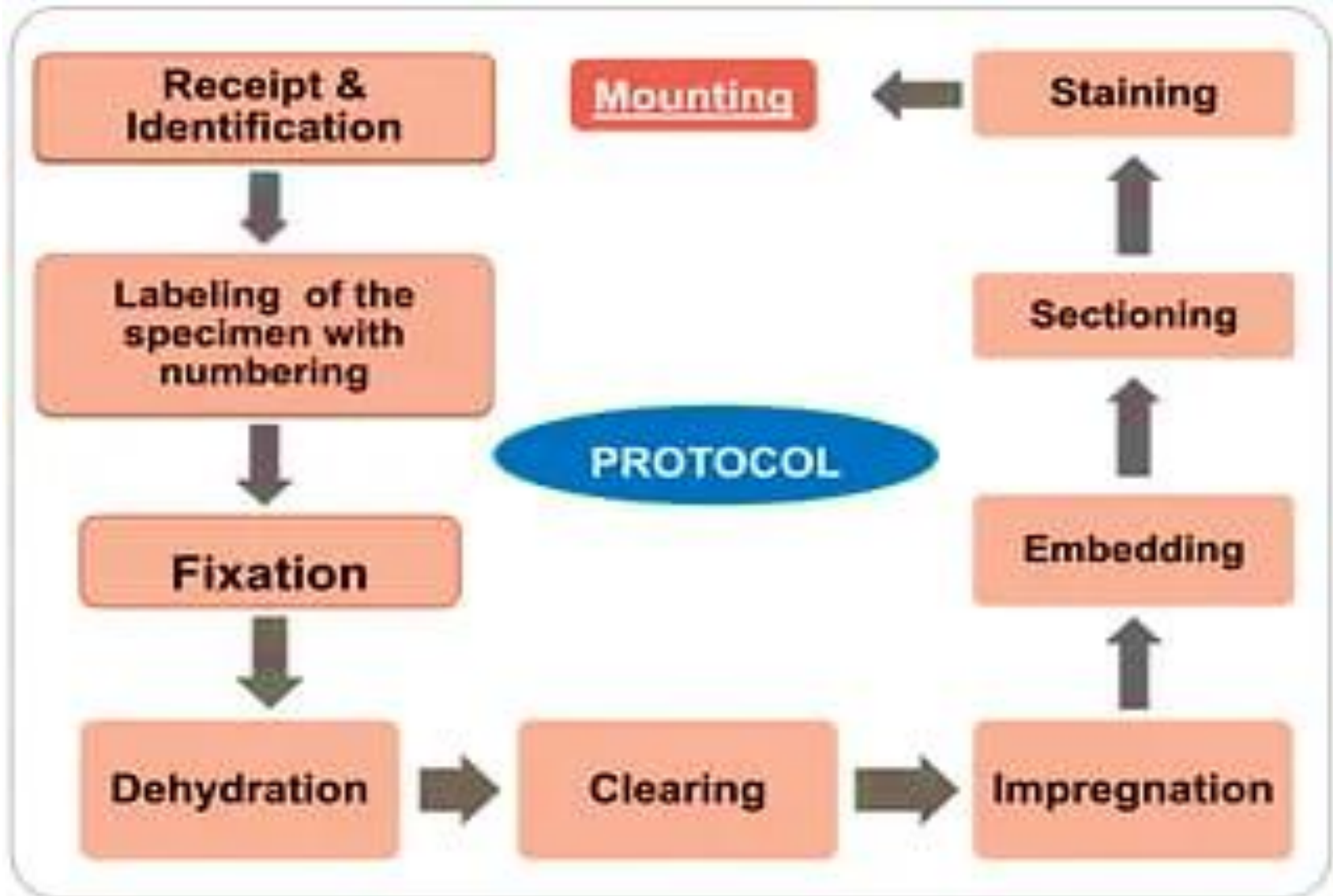

Fixation

- To maintain the structure of the tissue as in the life state
- upon removal from the body the sample Immediately placed in a fixative solution
- Fixation is done as soon as possible to prevent autolysis and to preserve the morphology.

For LM:

- Formol saline

For EM: a mixture of

- Glutaraldehyde
- Osmium tetroxide

ROUTINE FORMALIN FIXATIVES:

10% formal saline: Most commonly used fixative

Water (distilled) 900ml

Sodium chloride 8.5gm

Formalin 100ml

Advantage of the fixation step :

- Hardens the tissue by coagulating its protein → Facilitate the process of cutting & staining & examination
- Prevent putrefaction & stop autolytic changes by killing any bacteria
- Preserves the molecular & morphological structure of the tissue



Dehydration & Clearing

Dehydration : Is done by treating the specimen with ascending concentration of alcohol (50% → 70%→ 100%)
..... Gradual removal of water from the specimen (H₂O represent 70% of the body)

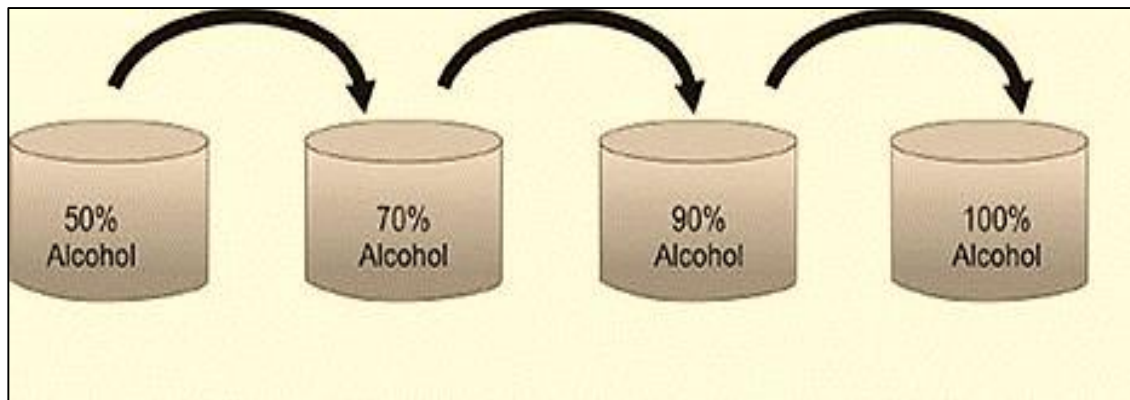

Clearing : with this process the tissue become translucent (to allow the light to penetrate the specimen)

the tissue is treated with xylol or benzol ...to remove the alcohol

Impregnation & Embedding

Impregnation :

- Tissues are placed in molten soft paraffin wax
- The wax infiltrates the tissue & occupies all the spaces that were originally occupied with water

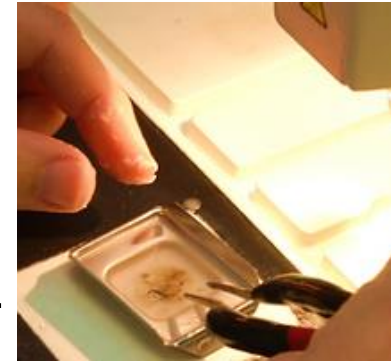

Embedding:

- Tissue are placed in molten hard paraffin wax
- The tissue is placed in the center of the paraffin, which hardens as it cools → paraffin block



Prof.Dr. Hala Elmazar

Impregnation

**Complete
Infiltration of the
tissue with wax**

**Essential for
production of
good sections**

Embedding

**Facilitates
sectioning**

**Prevents tissue
damage**

**Specimen
orientation is
very important**

Automatic tissue processor



The steps required to take animal or human tissue from fixation to the state where it is completely infiltrated with soft paraffin wax then to be embedded in hard wax for section cutting on the microtome.

Sectioning by Microtome



- A microtome is a mechanical device used to cut extremely thin slices of a fixed tissue block known as sections.
- It holds the block of hard paraffin with the tissue in its center against a sharp metal knife that used to cut the block into thin sections (3-10 microns) as it moves up and down.



mounting

Tissue sections are placed on glass slides smeared with egg albumin, then warmed on a hot plate to dry.

The sections are now ready to be stained



II. Freezing technique

Fresh frozen tissues are cut using **cryostat** (freezing microtome). The sections placed in cold fluid called Isopentane/liquid nitrogen (-50 C) for fixation then rapidly stained.

Advantages:

- Rapid technique for diagnosis in operation rooms (tumors).
- No fixation, No dehydration & No chemicals are used, so useful for histochemical (enzyme staining) studies.

Disadvantages:

- Non serial & Fragmented sections .
- Cannot be preserved for a long time.

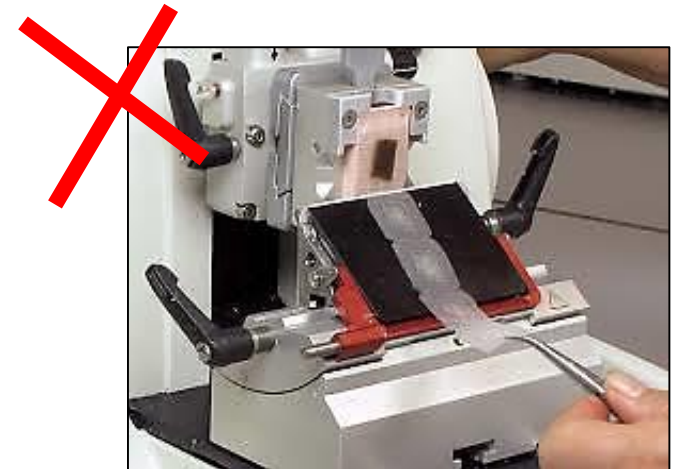

Staining

- The tissue sections that will be studied using the light microscope must be stained first since most tissues are colorless
- Dyes (stains) used are either **basic** or **acidic**

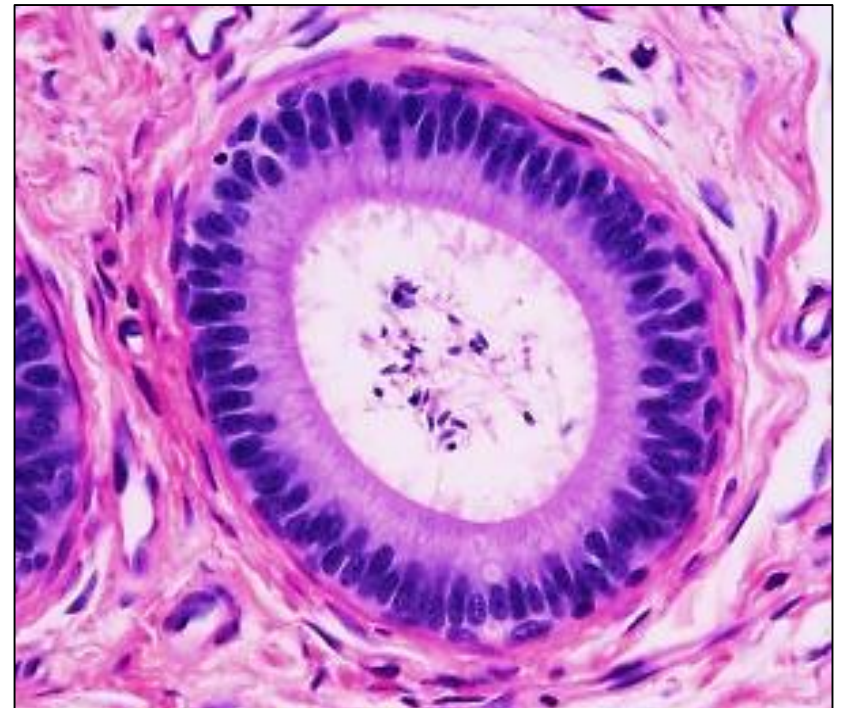
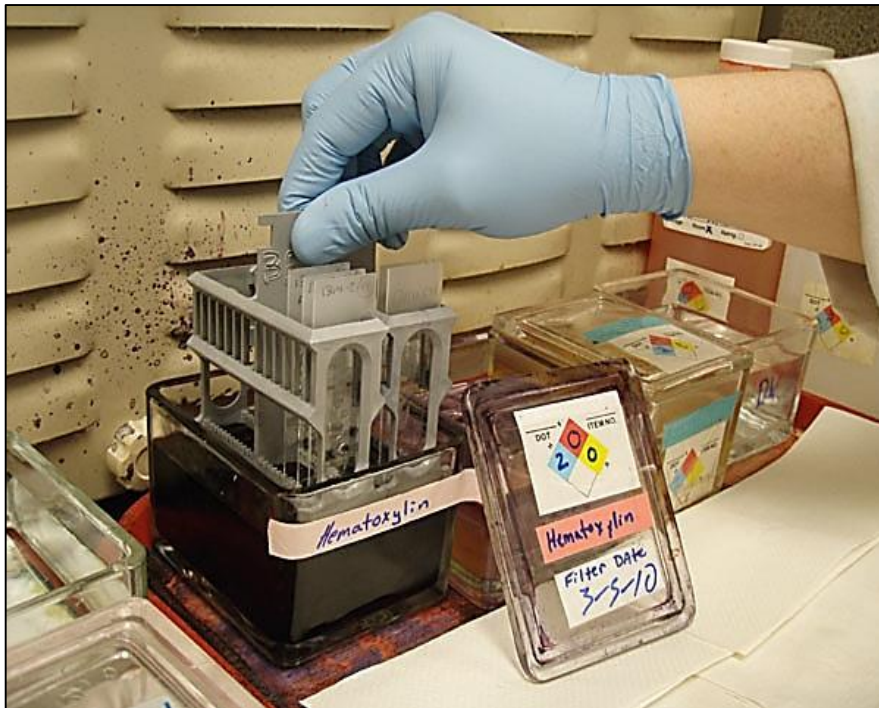

Staining

Used to visualize & distinguish the different parts of cells & tissues

Routine stains
H&E

Special stains
e.g. Ag & orcein,
trichrome...etc

Common (Routine) histological stains H&E

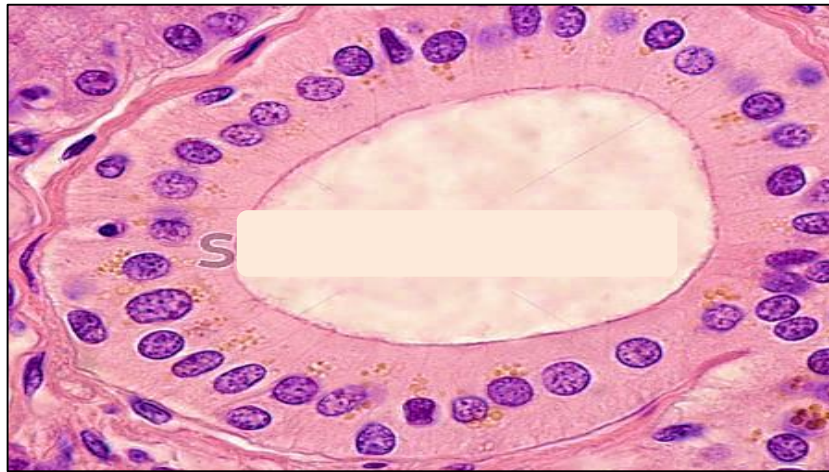

- **Hematoxylin (H) :**
blue basic dye (+ve charged)
- Stains acidic (anionic -ve) components of the cell with a blue color e.g. nucleus, ribosomes (r-RNA)

Basophilic structure=blue

- **Eosin (E):**
red acidic dye (- ve charged)
- Stains basic (cationic +ve) components of the cell with a red color e.g. cytoplasm, mitochondria, muscles !!
(it has +ve charged proteins)

Acidophilic structure=red

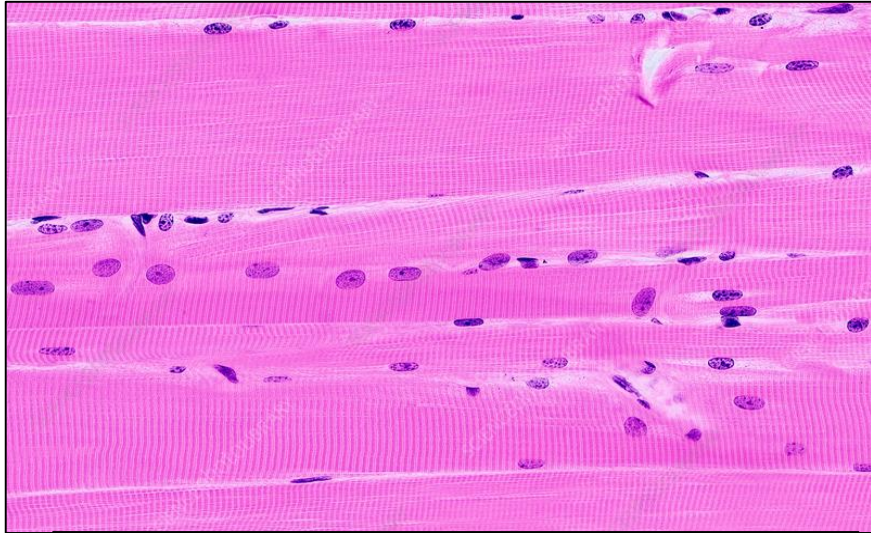

L.S skeletal ms. fiber (contains actin & myosin) stained with H &E

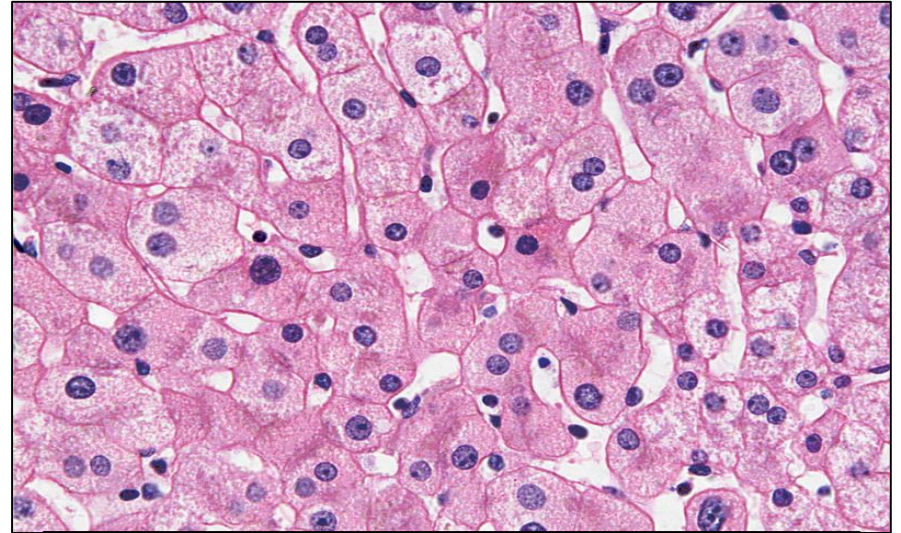

Liver cells contains plenty of mitochondria stained with H &E

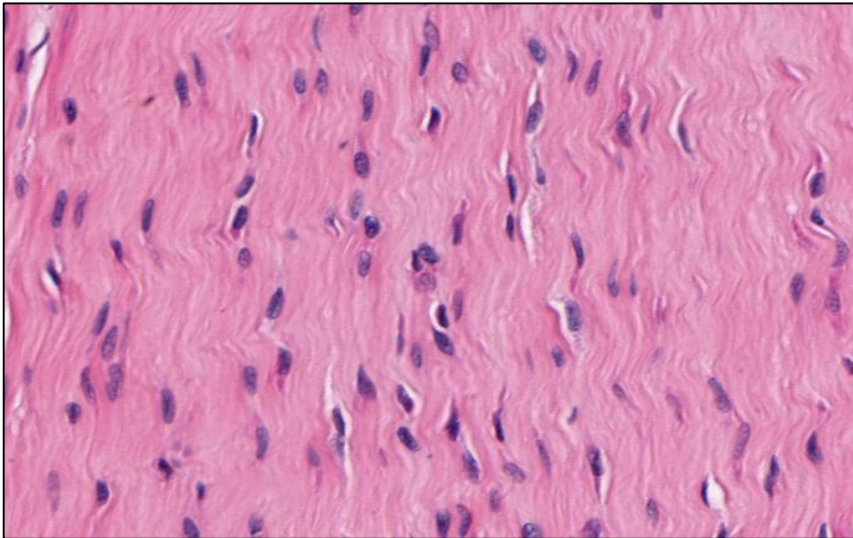

Collagen fibers stained with H & E



Automatic slides staining machine

The clinical values of **special stains**

- Special stains answer specific questions like what type of cells and tissues
- Also Used in the diagnosis of medical diseases like Tichrome stain in case of Liver Cirrhosis

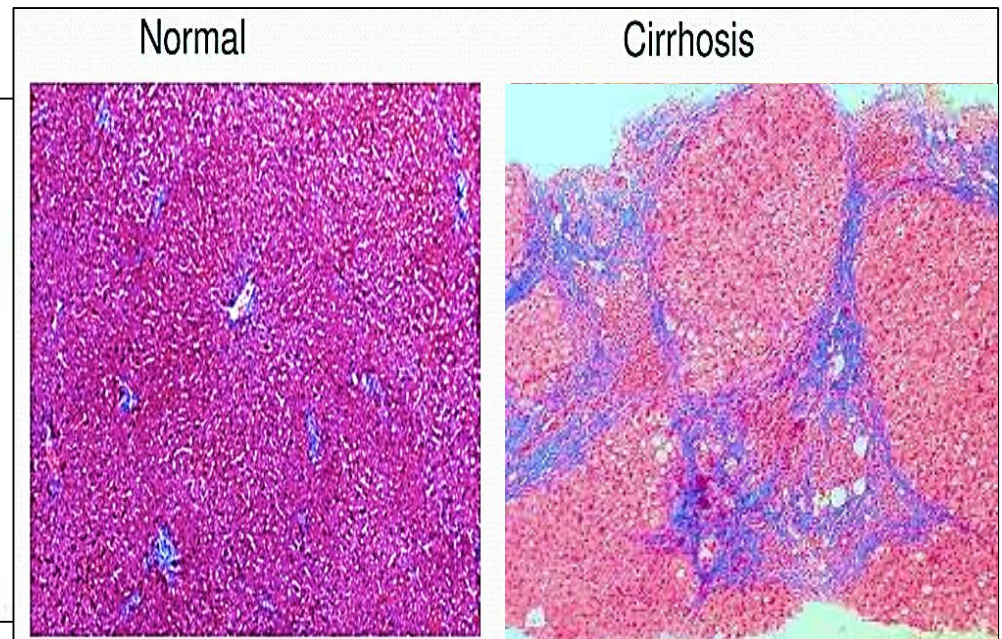
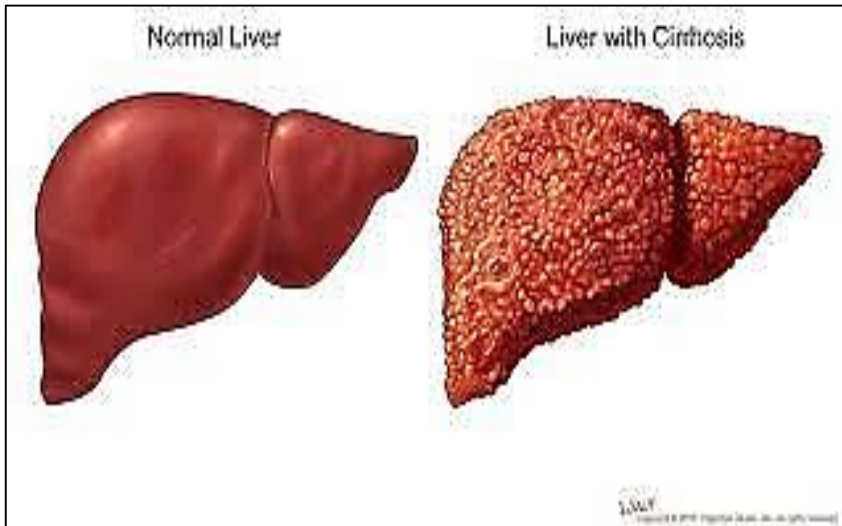

Vital stain: (test the viability of the cell)

Stain the living cells inside the living animal. Done by injecting the dye into living animal prior to examine the tissue .e.g. staining phagocytic cells (macrophages) with **Trypan blue** & **Indian ink**



Leishman stain:

mixture of acidic & basic stains to stain nuclei & cytoplasm

(methylene blue & Eosin) It is used to stain blood films to demonstrate white blood cells e.g. malaria parasite

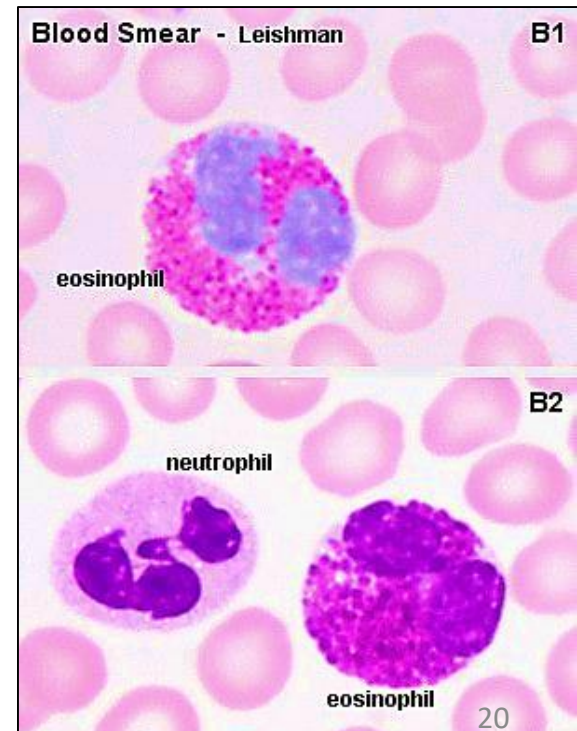

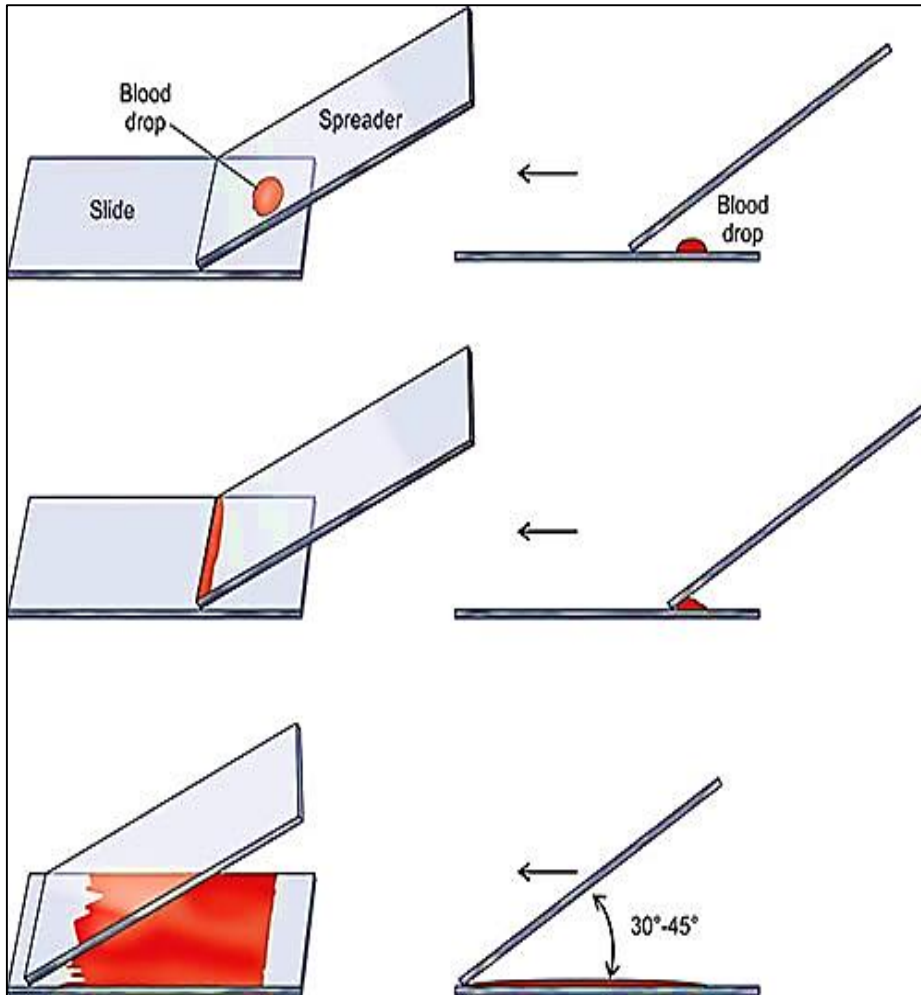

Technique of blood film

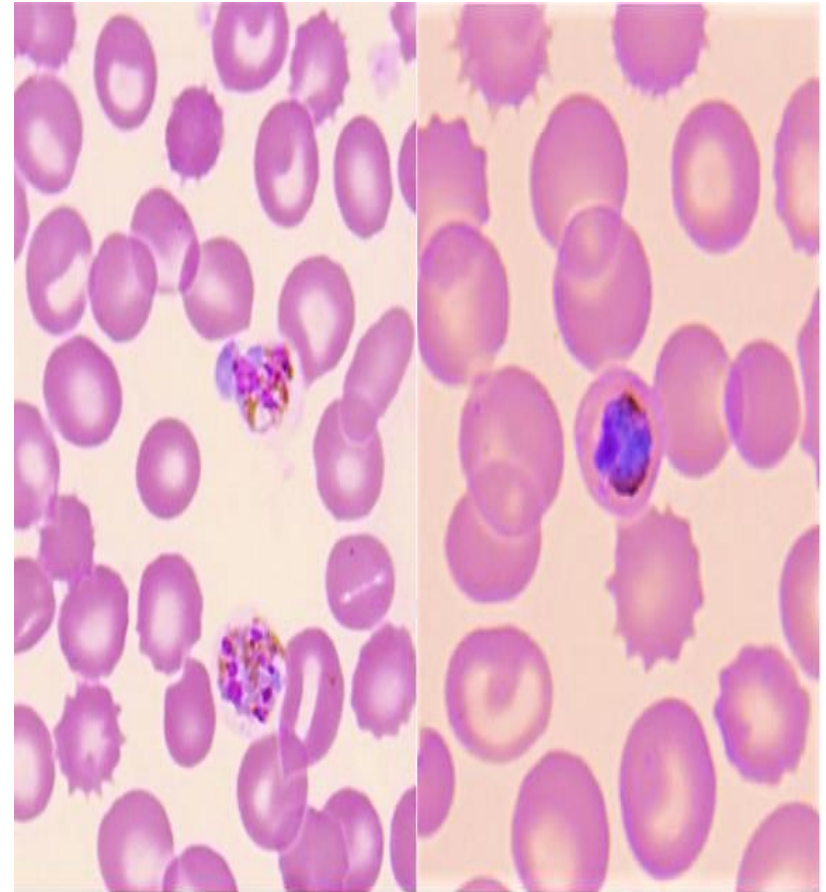

Red blood cells infected with malaria parasite

Metachromatic stain:

Stain gives the tissue new color different from that of the original stain e.g. **Toluidine blue** when stains Mast cells gives purple color (different from the blue color of the stain). Phenomenon called **metachromasia**.

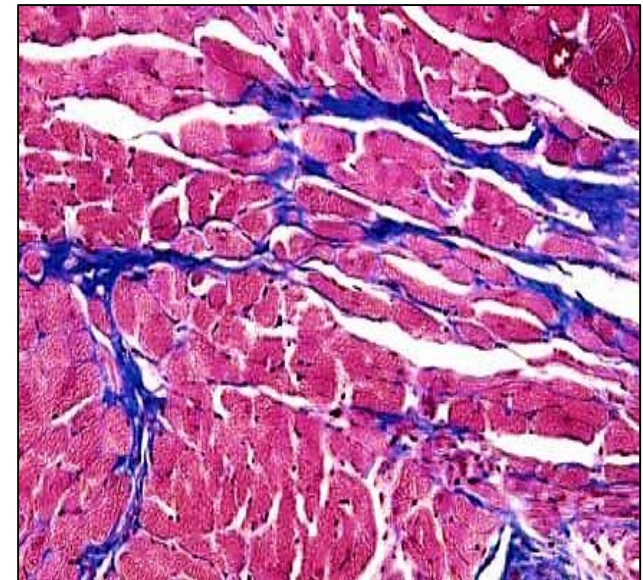
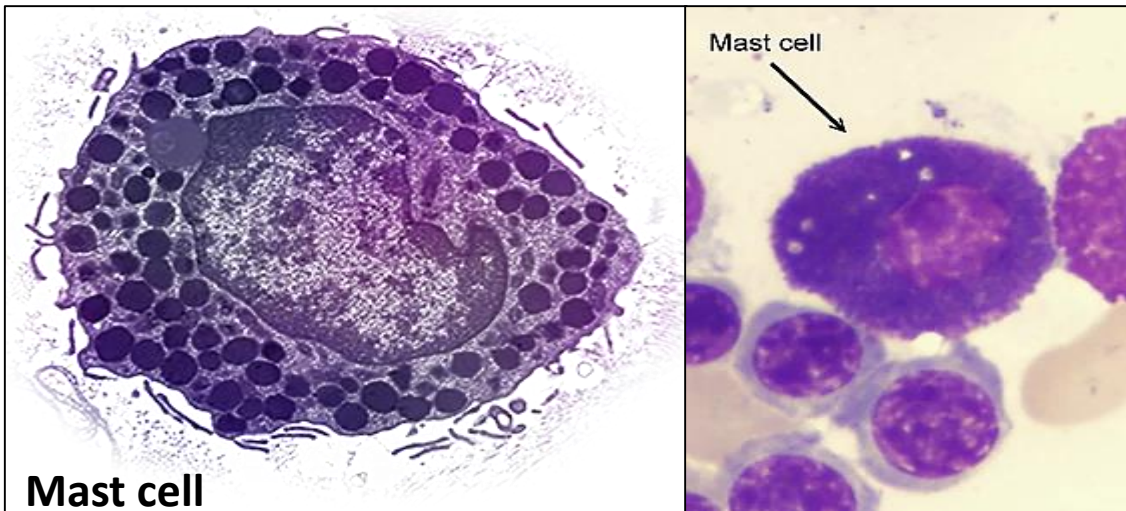

Trichrome stains: (connective tissue)

3 stains used in combination to stain different tissues
Components e.g. **collagen fibers** stained blue

Orcein stain : stains elastic fibers brown (wall of aorta)

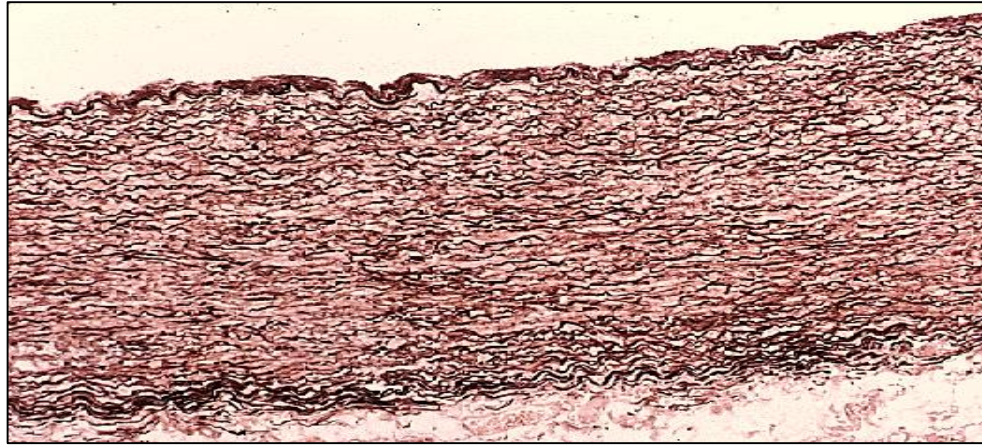

Silver (Ag) stain: nerve cell brown & reticular fibers black

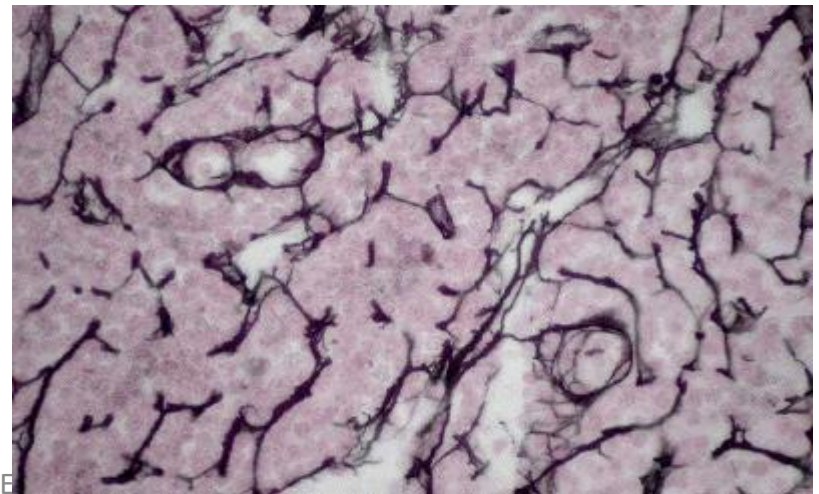
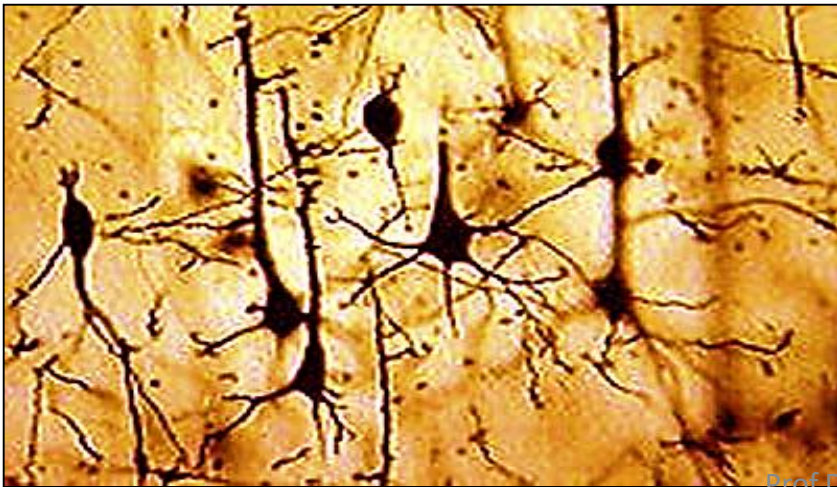

- **Histochemical stains:** (Relate structure to function)

technique used selectively identify & demonstrate the distribution of chemical compounds or enzymes within & between the cells e.g. mucine or alkaline phosphatase enzyme

Concept: enzyme of interest in a cell or tissue converts its substrate → colored or fluorescent product that can be visualized at the site of the activity

- **Immuno-histochemical (IHC) stains:**

cryostat

Laboratory method that selectively identify antigens using specific antibodies to check for these antigens in a sample of tissue. The antibodies are usually linked to an enzyme or a fluorescence dye (markers) (Labeled antibodies).



Histochemical stains

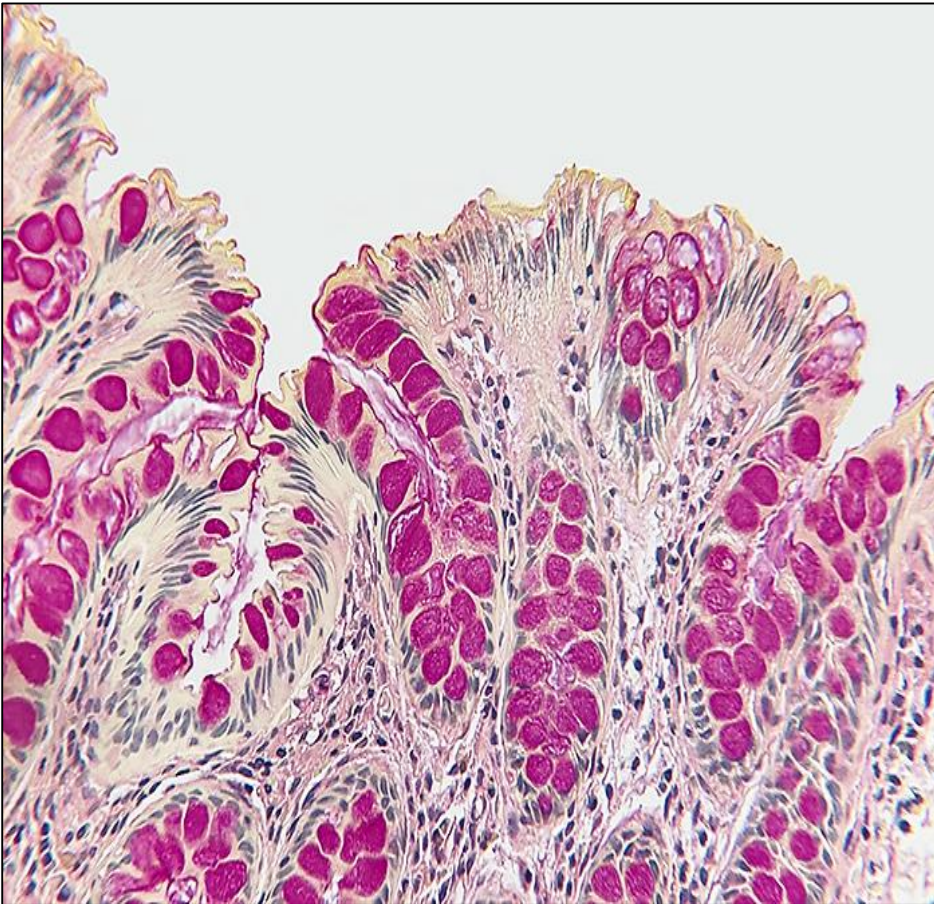

for mucin in mucous cells



(Alkaline phosphatase enzyme)
(this enzyme removes phosphate group
from protein)

- After the antibodies are linked to the antigen in the tissue sample the enzyme or dye is activated. The localization of the antigen can be seen under the microscope
- This is method is use for visualize both normal & disease status of tissue
used in diagnosis of cancers (markers) and can tell the difference between different types of cancer . Tumor specific

Use of the Immunohistochemistry:	
• Intercellular antigens,	• Diagnosis of the endocrine tumors
• Cell surface antigens,	• Small amounts of peptides in endocrine or neuroendocrine cells
• Tissue antigen for diagnosing autoimmune diseases	• Immunodeposits
• Protein hormones in histopathological diagnosis	• Tumoral markers
• Soluble antigens of the cell	• Tumor typing

- Indirect vs direct IHC

direct is ideal for detecting highly expressed antigens

while Indirect is more suitable for poorly expressed antigens which benefit from signal amplification by the secondary antigen

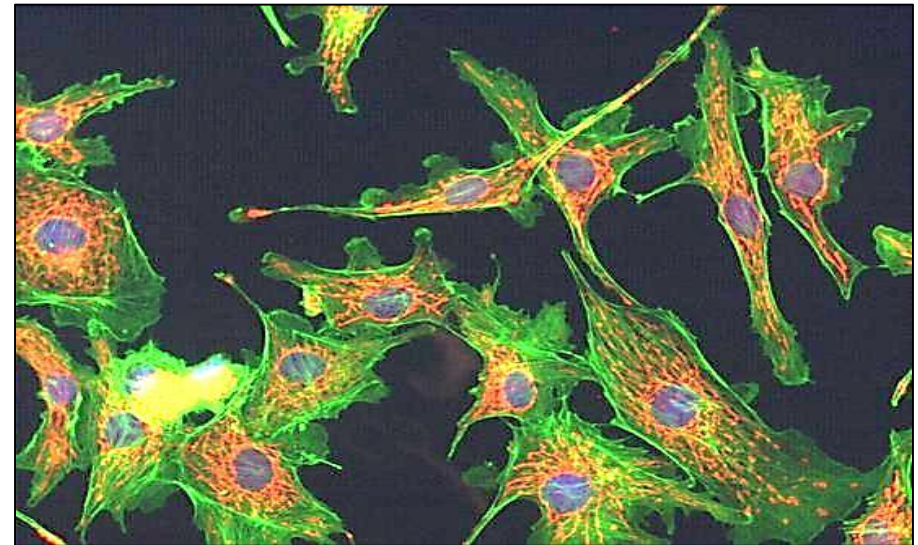
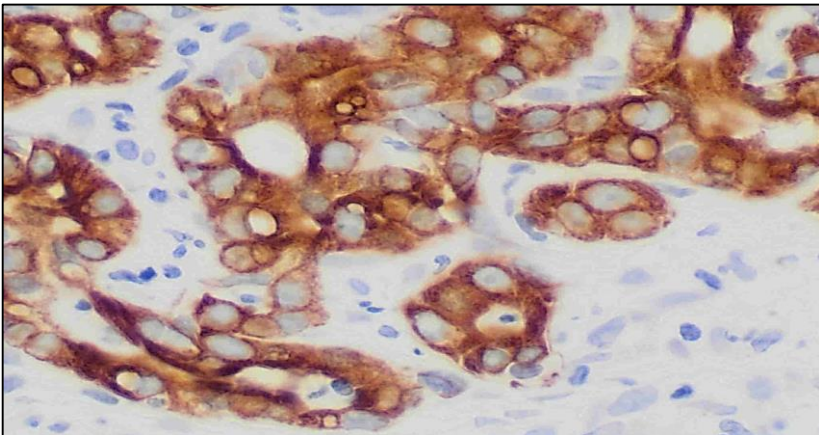
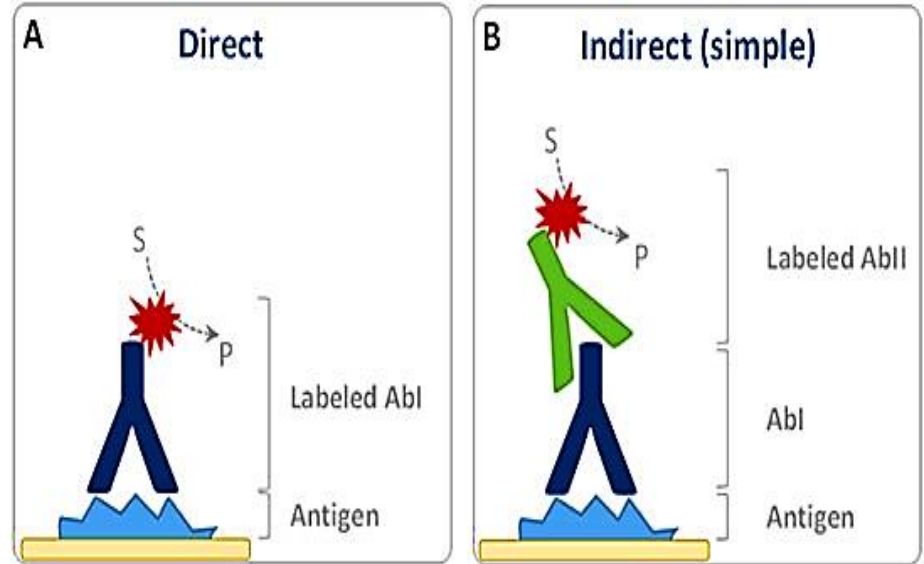

Immunohistochemistry (IHC)

Molecular analysis

It means **biochemical analysis** of certain components of the cell. It is usually quantitative in nature.

Examples are:

- Protein-electrophoresis
- DNA – electrophoresis
- Fluorescent In situ hybridization (FISH technique)
- Detection of certain ions in the cell e.g. Ca, Fe....etc.

Protein electrophoresis:

Proteins carry a **positive** or a **negative** electrical charge, and they move in fluid when placed in an electrical field. Proteins will be separated according to their charge & molecular weight

(e.g. blood cancers: ↑ increased gamma globulin protein (M protein) = multiple myeloma)

DNA electrophoresis: is technique used to identify & quantify DNA fragments (DNA fragments are -ve charged).

(in this case separation is based on length of the base pair)

Samples are loaded into wells of an **agarose** or **acrylamide gel** and subjected to an electric field, causing the negatively charged nucleic acids to move toward the positive electrode.

Small fragments will move faster than the large ones

(**DNA fingerprint , gene isolation, disputed paternity**)

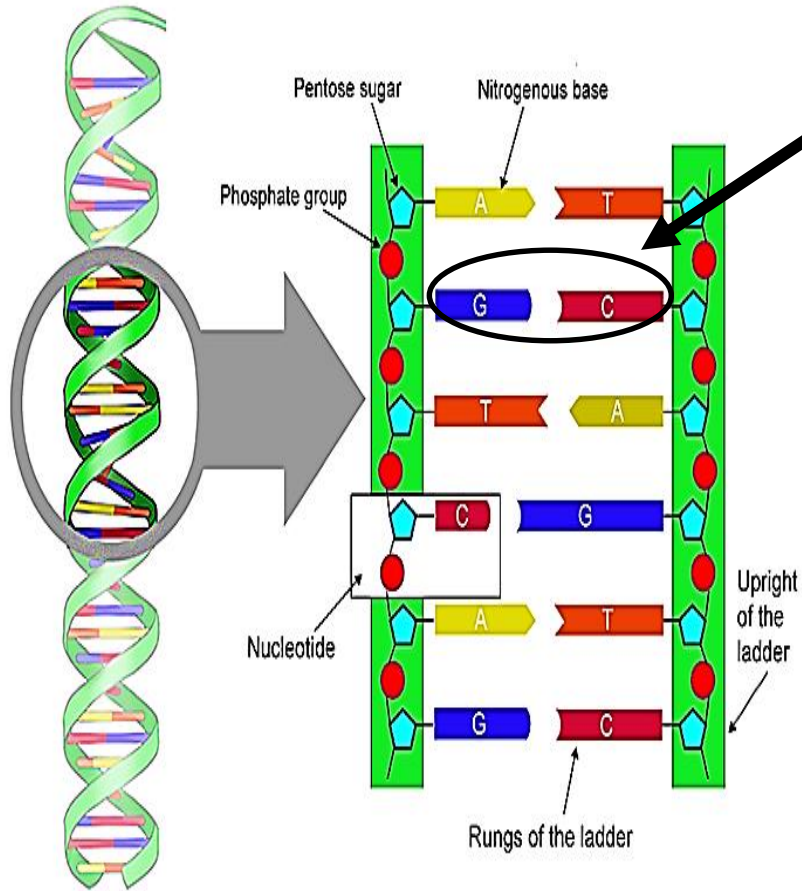

A base pair: is a unit consisting of two nucleobases bound to each other by hydrogen bonds.

They form the building blocks of the DNA double helix.

Sequence of bases on DNA determine genetic code for a trait

The human genome contains approximately 3 billion of these **base pairs**, which reside in the 23 **pairs** of chromosomes within the nucleus of all our cells

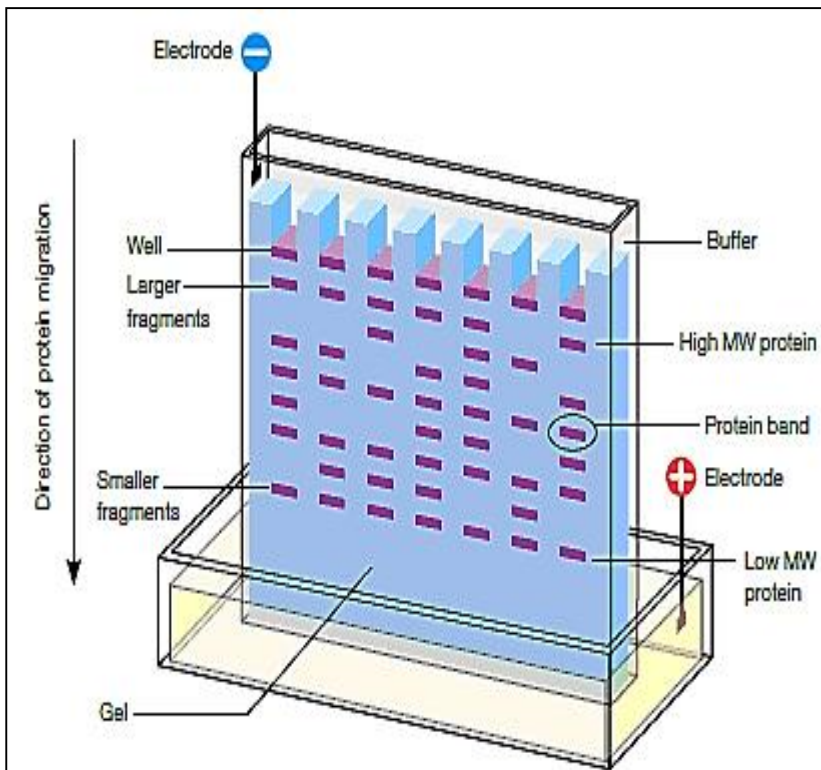
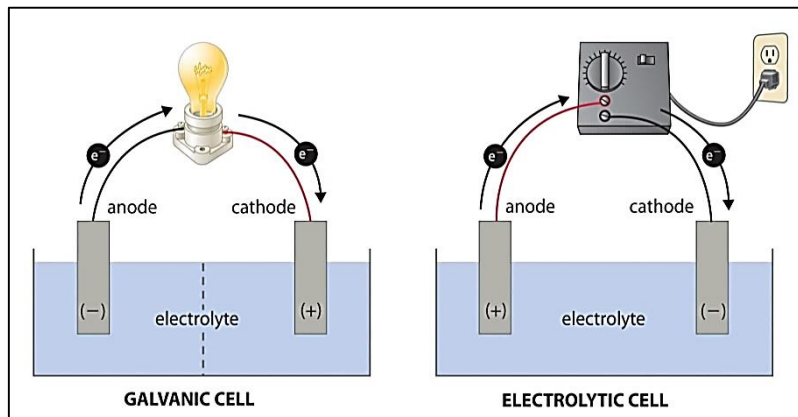

Protein electrophoresis

DNA Ladder: DNA fragments of known lengths used to estimate the size of unknown DNA molecule

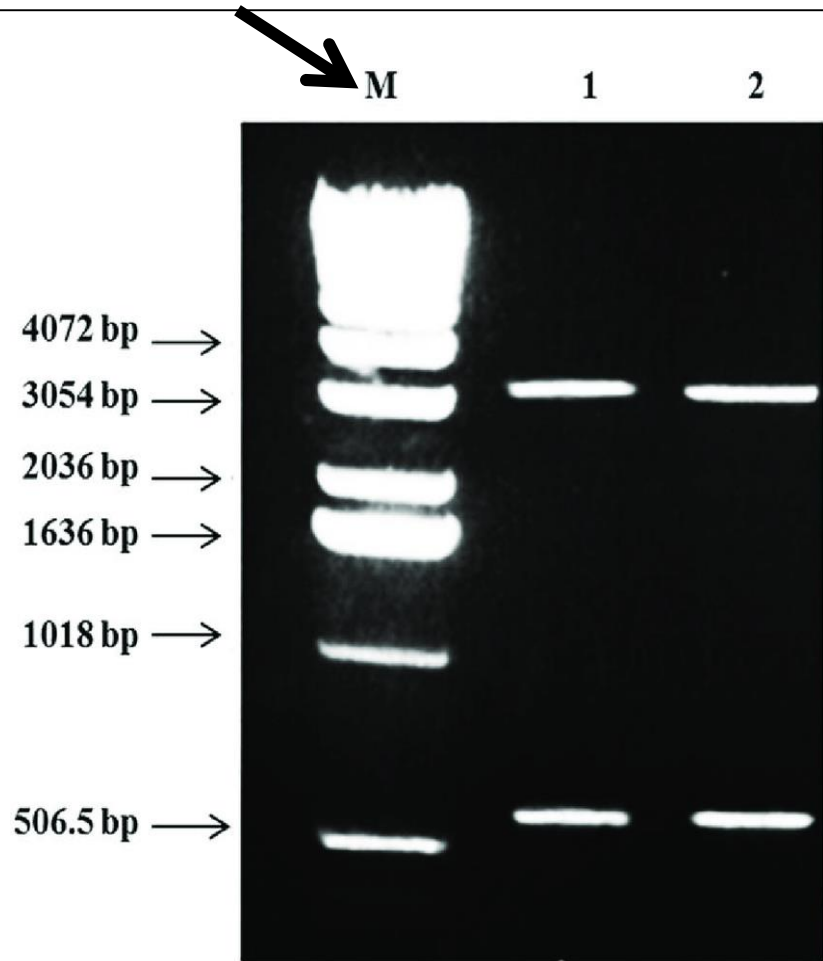

Fragment size usually referred to as base pair (bp). The shorter fragments travel faster

Fluorescent In situ hybridization (FISH technique):

Molecular technique used to visualize and map the genetic material. Use to localize the site of the genes on chromosomes using a fluorescent probe

fluorescent probe:

fragment of DNA or RNA of variable length which can be radioactively labeled (**probe**)

It can be used in DNA or RNA samples to detect the presence or absence of a nucleotide sequence that are complementary to the sequence on the probe .

Useful in detect chromosomal abnormalities

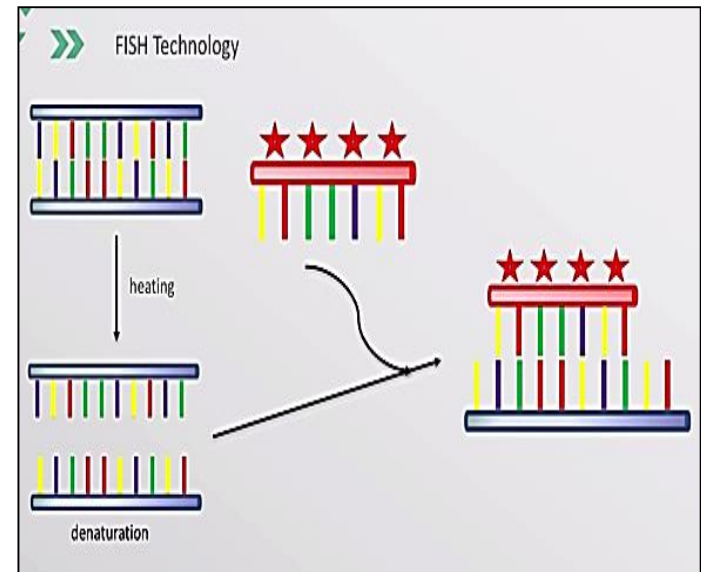

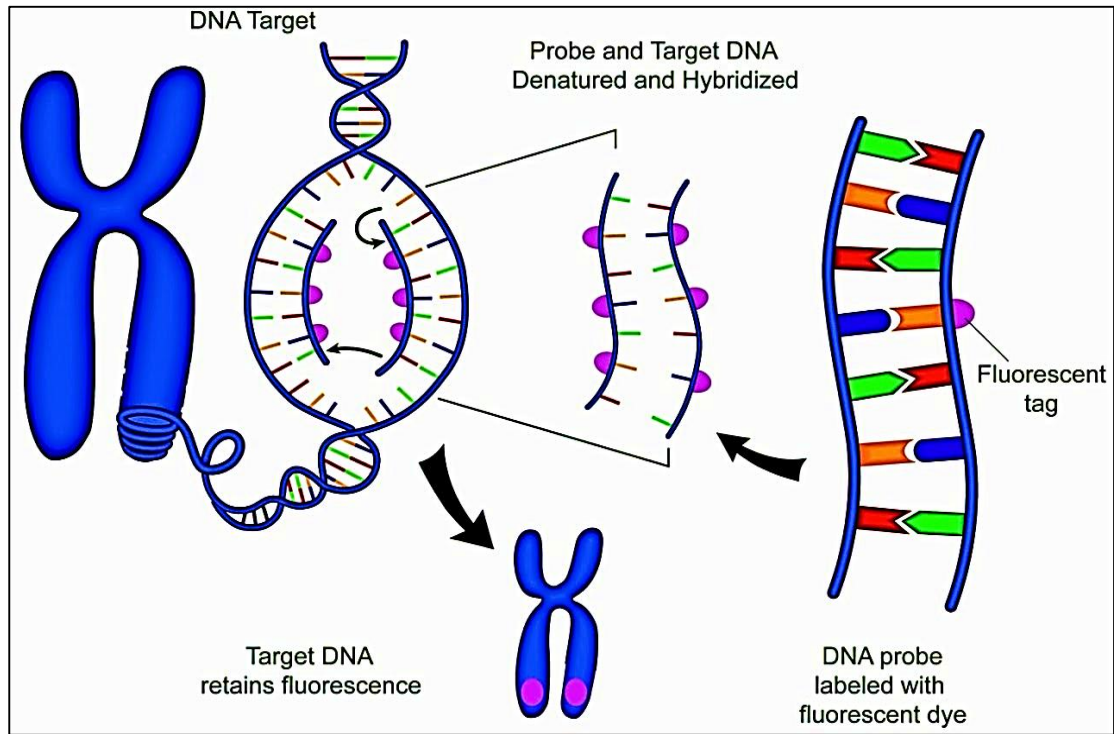

Methods for study tissues

- **1-In vivo studies: within the living body** . Study of tissues after doing any experiment inside the living body (animal model based testing)

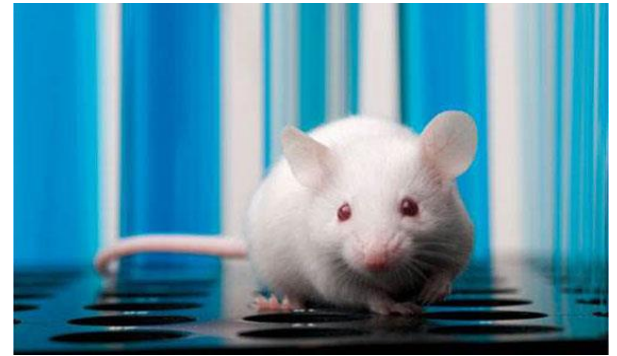

- **2-In vitro studies: outside the body** Study of tissues outside their normal biological context (cell based testing)



Cell and Tissue Culture

- **In vitro** cultivation of tissues & cells at defined temperature(37C) using an incubator & supplemented with a medium containing cell nutrients & growth factors(like animal serum) is collectively known **as tissue culture.**
- Different types of cells can grow in cultures as: white blood cells, fibroblasts, skeletal and cardiac muscle, epithelial tissue (liver, breast, skin, kidney) and many different types of **tumor cells.**

Medical uses of tissue culture:

1- used in studying chromosomal patterns of individuals
Karyotyping, gene therapy

2- Used in researches of cancer

3- Used in cultivation of bacteria, viruses, in order to
prepare different vaccination

4- Study the effects of new drugs



Cell culture

Cells can be isolated from the body for ***in vitro* cultures**. **Cells** can be released from **tissues** by enzymatic digestion **Using enzymes** such as collagenase and trypsin which break down the extracellular matrix.

Primary cultures:

Refer to the cells that are cultured directly from a tissue (parent cells).

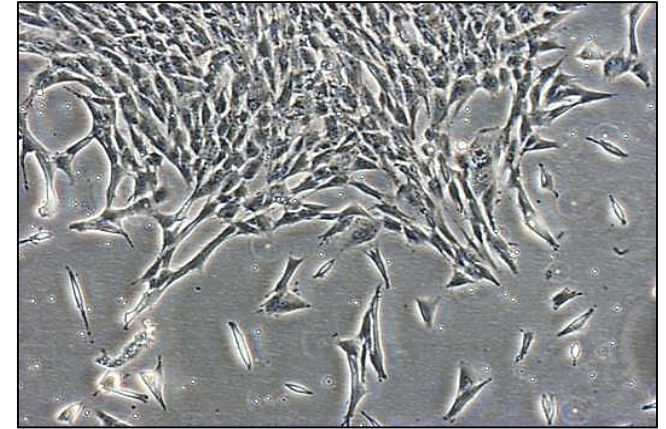

Secondary cultures:

- Once the parent cells reach confluence they have to be **sub-cultured** (i.e. passaged) by transferring them to a new vessel with fresh growth medium to provide more room for continued growth

Confluence:

- stage in which the cells (1ry or 2ry) become adherent to & covering most of the culture surface forming monolayer(e.g. 25%, 50%, 100%)

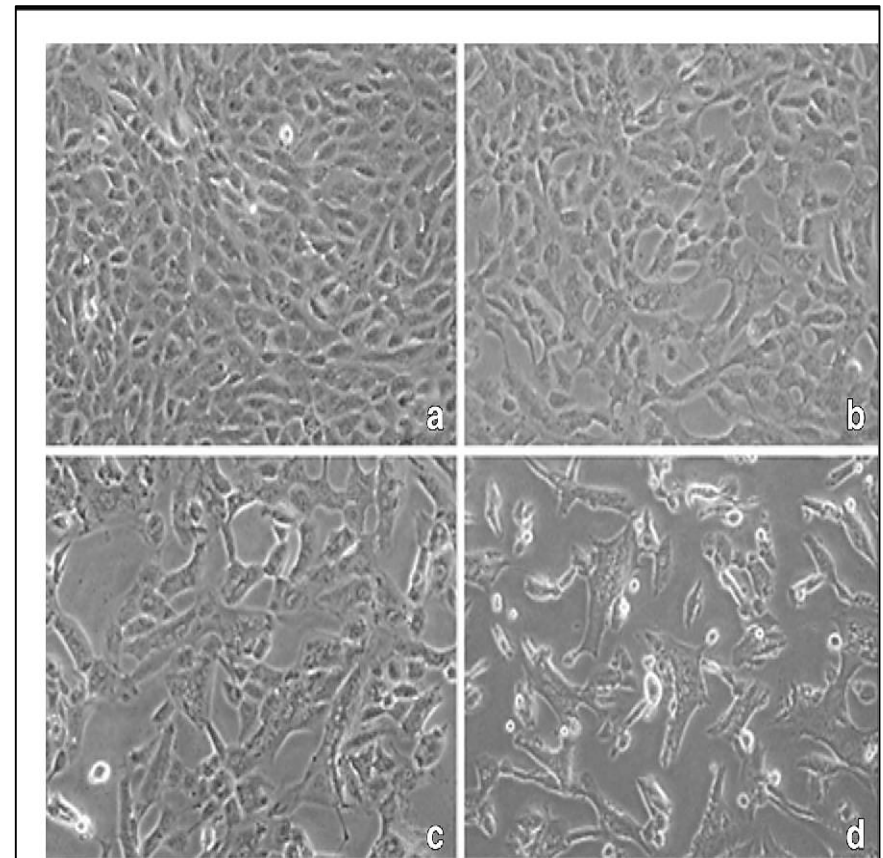
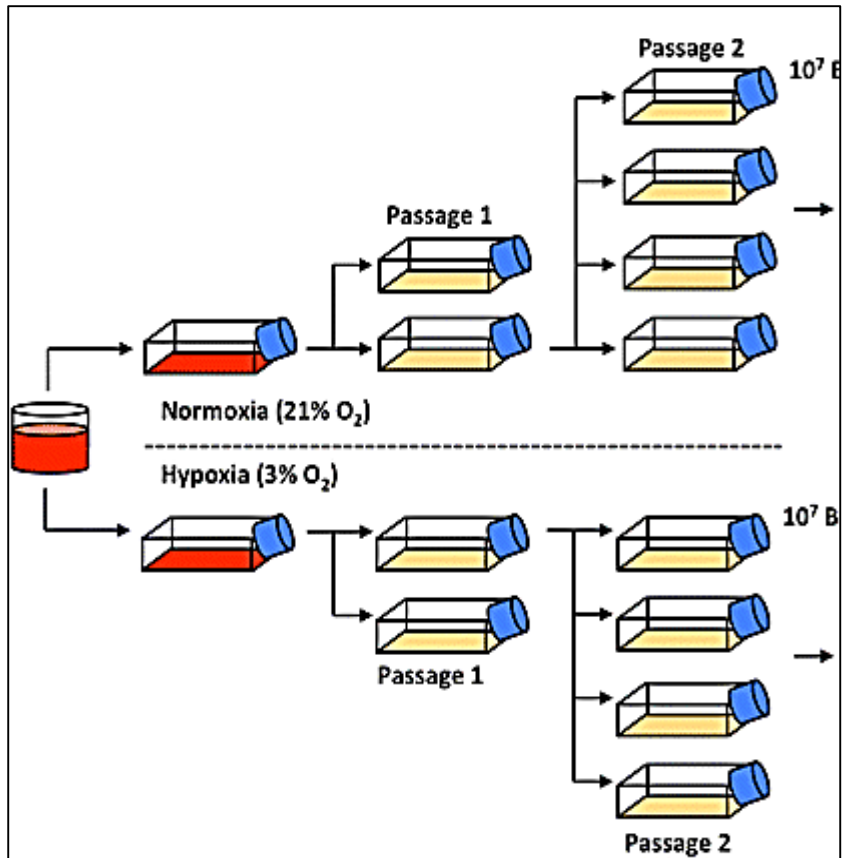

Cell passage = subculture

Different degrees of confluency

cell line:

- a population of cells (clone) developed from a single cell therefore these cells have a uniform genetic make-up (phenotype & function)
- Cell lines have a limited life span, and as they are passaged

immortalized cell line

- Has acquired the ability to **proliferate indefinitely.**
- It is obtained from subcultures of the primary culture
- Normal immortalized cell line: stem cells
- Abnormal immortalized cell lines : cancer cells

Cell fractionation

- It means isolation of the cell components (nucleus & organelles) while preserving its individual function to study the features of each.
- This is done by the use of **centrifugation** at different speeds and periods of time. The factor that determine whether a specific cell component ends up in the supernatant or the pellet is size and weight of component
- Nuclei are the first to be separated followed by different cell organelles

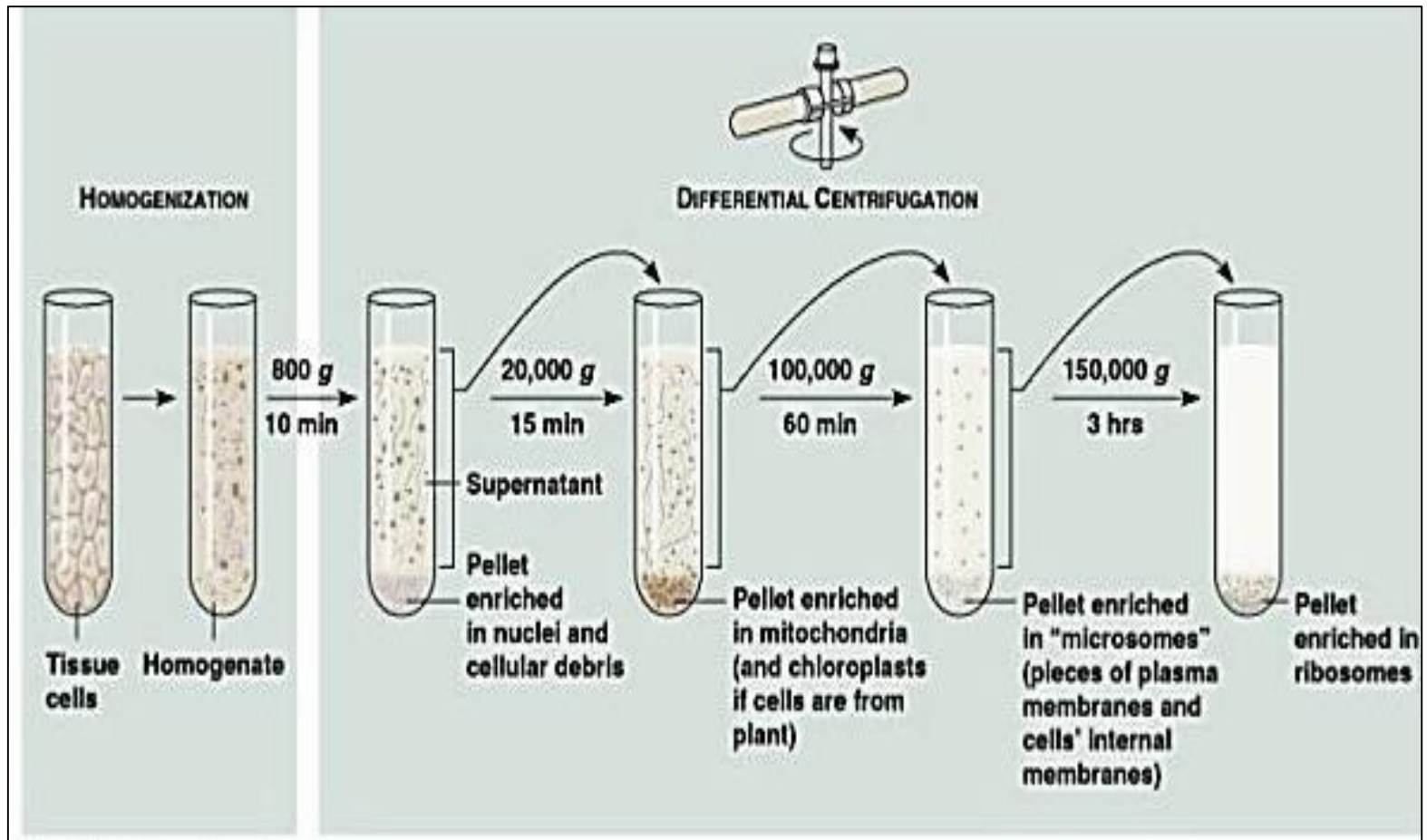

The sediment at the bottom of the tube is called **pellet**, the less dense component at the top is called **supernatant**

Thank you

